

# Isolating transformer ES710

Single-phase isolating transformers for the design of medical IT systems

**Also available as energy-efficient Green Line (GL) edition**



# Isolating transformer ES710

Single-phase isolating transformers  
for the design of medical IT systems



## Device features

- Built-in temperature sensors acc. to DIN 44081 (120 °C)
- Screen winding with brought-out insulated connection terminal
- Insulated mounting angles
- Degree of protection, IP00 (open design)
- Degree of protection, IP23 (with enclosure)
- Protection class I
- Protection class II (option: encapsulated version)
- Reinforced insulation
- Temperature class:  $t_a40/B$
- UL insulation system: class F
- Connections: screw terminals
- Noise level < 35 dB (A) (no-load and nominal load)
- Vector group: li0
- Inrush current  $I_E$  GL version <  $5 \times \hat{I}_n$

## Approvals



VDE test mark for all types:

- ES710/3150 - ES710/10000
- ES710/3150S - ES710/10000S
- ES710/3150SN - ES710/10000SN
- ES710/3150-GL - ES710/10000-GL
- ES710/3150S-GL - ES710/10000S-GL
- ES710/3150SN-GL - ES710/10000SN-GL



## Application and description

The transformers of the ES710 series have reinforced insulation and comply with the requirements of DIN EN IEC 61558-1 (VDE 0570-1) and DIN EN IEC 61558-2-15 (VDE 0570-2-15).

In addition, the transformers comply with the requirements of IEC 60364-7-710/DIN VDE 0100-710 (VDE 0100-710) for IT systems in medical locations. The windings are galvanically isolated. In order to minimize electrical interferences, an electrostatic screen is installed between the primary and secondary winding the lead out of which is connected to an insulated terminal for connection to the equipotential bonding.

The fixing angles are isolated from the transformer core in order to guarantee an isolated installation.

The transformers are available for horizontal and vertical installation. Protection against corrosion is guaranteed by a complete resin impregnation.

The transformers are designed for use in dry locations. Transformers of the SK2 series are completely encapsulated and fulfil the requirements of protection class II.

## Frequency/ratings

The transformers are designed for rated frequencies of 50...60 Hz. The values specified in the chapter "Technical data" refer to a maximum ambient temperature of 40 °C and a rated frequency of 50 Hz.

## Temperature rise

Free air circulation must be ensured. An ambient temperature exceeding 40 °C will reduce the rated power. For temperature monitoring, a PTC thermistor is placed on each transformer leg and the leads are connected to the terminals.

## Enclosure

Appropriate steel sheet enclosures, degree of protection IP 23, are available for all standard types of isolating transformers.

## Rated power

According to DIN VDE 0100-710 (VDE 0100-710), the rated power of the transformer shall not be less than 3.15 kVA and shall not exceed 8 kVA.

## Overload protection

When isolating transformers are used to form a medical IT system in accordance with para. 710.531.2.4.101 of DIN VDE 0100-710 (VDE 0100-710), **overload protection is not permitted**. In this case, short-circuit protection is required. That means, emphasis is focused on the availability of the power supply; it is therefore essential to avoid disconnection on the occurrence of transient overload. The protection of isolating transformers against overload and overtemperature can be realized by using monitoring devices in accordance with para. 710.531.7. The appropriate fuses for short-circuit protection can be selected from the table "Technical data".

## Standards

ES710 isolating transformers comply with the device standards and the regulations for installation:

- DIN EN IEC 61558-1 (VDE 0570-1)
- IEC 61558-1
- DIN VDE 0100-710 (VDE 0100-710)
- DIN EN IEC 61558-2-15 (VDE 0570-2-15)
- IEC 61558-2-15
- IEC 60364-7-710.

Extension of VDE certification for GL version tested and certified in accordance with:

- DIN EN 61558-1 (VDE 0570 Part 1); EN 61558-1
- DIN EN 61558-1/A1 (VDE 0570 Part 1/A1); EN 61558-1/A1
- DIN EN 61558-2-15 (VDE 0570 Part 2-15); EN 61588-2-15.



**Hazard warning:**

When performing installation work in the environment of the transformer, it has to be ensured that the insulation coordination of the transformer is not influenced in a negative way. For example, no ferromagnetic and conductive metal swarf may fall down close to the transformer. This can interfere with the function and the dielectric properties, especially after being turned on. The environment of the transformer must be kept free from such particles during the entire operating time and controls must be carried out at regular intervals.

**Nameplate**

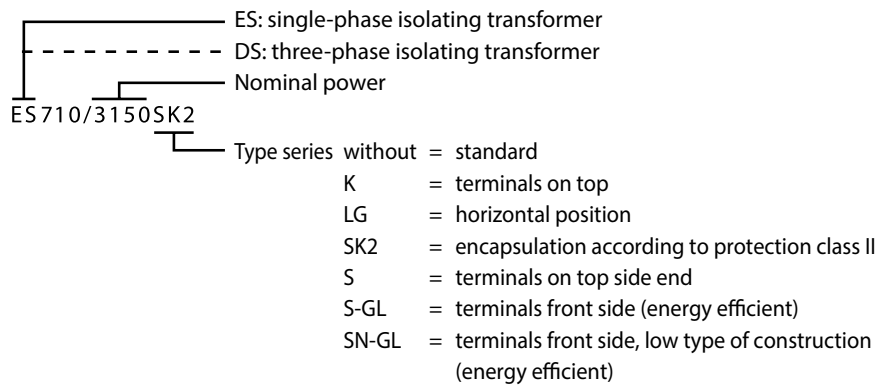

**Wiring diagram**

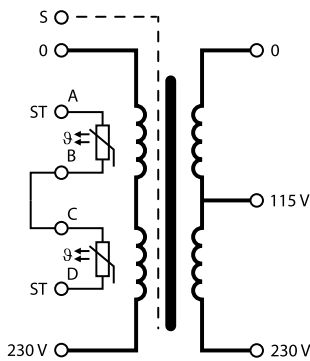

**Terminal diagram**

Standard, K series, LG series, S series, S-GL series, SN-GL series

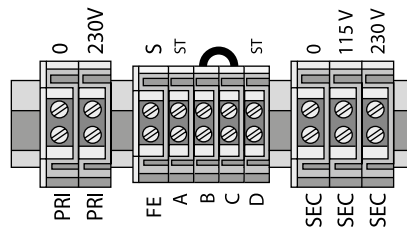

SK2 series

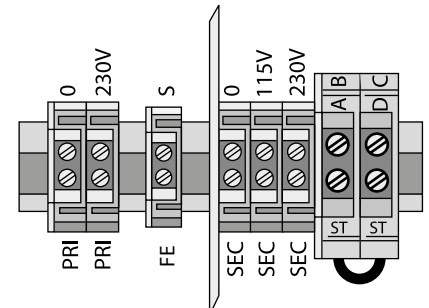

**Connection properties**

Type	Input terminals flexible/rigid	Screen winding flexible/rigid	Control terminals flexible/rigid	Control terminals for protection class II flexible/rigid	Output terminals flexible/rigid
ES710/3150	16/25 mm <sup>2</sup>	16/25 mm <sup>2</sup>	4/6 mm <sup>2</sup>	2.5/4 mm <sup>2</sup>	16/25 mm <sup>2</sup>
ES710/4000	16/25 mm <sup>2</sup>	16/25 mm <sup>2</sup>	4/6 mm <sup>2</sup>	2.5/4 mm <sup>2</sup>	16/25 mm <sup>2</sup>
ES710/5000	16/25 mm <sup>2</sup>	16/25 mm <sup>2</sup>	4/6 mm <sup>2</sup>	2.5/4 mm <sup>2</sup>	16/25 mm <sup>2</sup>
ES710/6300	16/25 mm <sup>2</sup>	16/25 mm <sup>2</sup>	4/6 mm <sup>2</sup>	2.5/4 mm <sup>2</sup>	16/25 mm <sup>2</sup>
ES710/8000	16/25 mm <sup>2</sup>	16/25 mm <sup>2</sup>	4/6 mm <sup>2</sup>	2.5/4 mm <sup>2</sup>	16/25 mm <sup>2</sup>
ES710/10000	35/35 mm <sup>2</sup>	35/35 mm <sup>2</sup>	4/6 mm <sup>2</sup>	2.5/4 mm <sup>2</sup>	35/35 mm <sup>2</sup>

**Dimension diagram/type of construction**

Standard

Dimension B is the depth incl. terminals

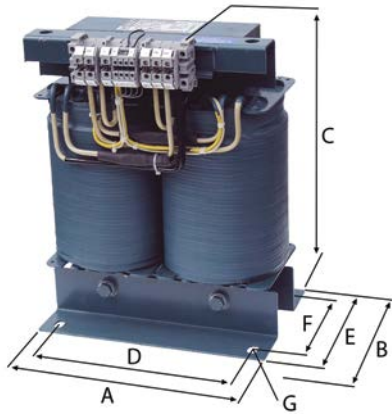

SK2 series

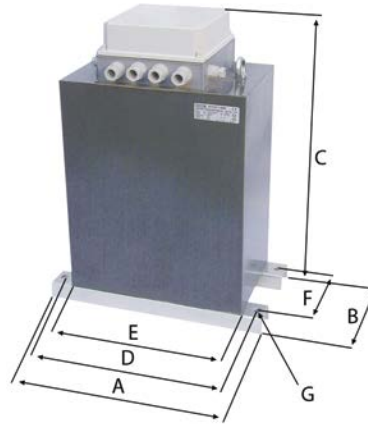

S series

Dimension E is the depth incl. terminals

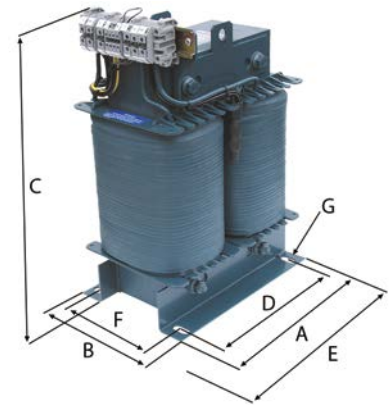

K series

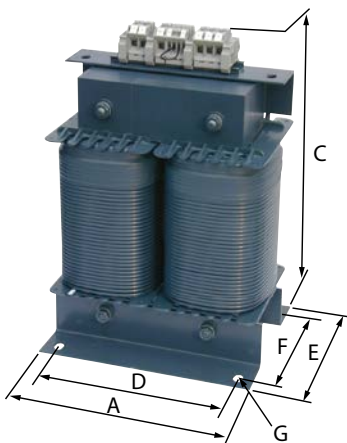

LG series

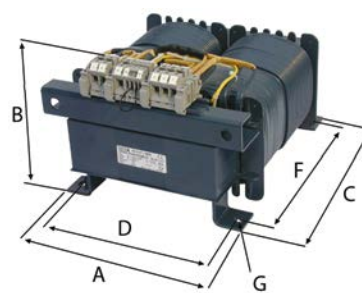

SN-GL series

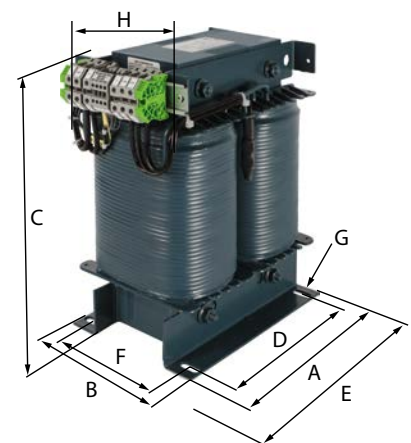

**Ordering information**

	Dimensions (mm)							Cu weight (kg)	Weight (kg)	Type	Art. No.
	A	B	C	D	E	F	G				
GL series	240	230	325	200	180	145	11 x 28	15	49	ES710/3150-GL	B92090001
	280	200	370	240	150	115	11 x 28	24	59	ES710/4000-GL	B92090002
	280	210	370	240	160	125	11 x 28	25	61	ES710/5000-GL	B92090003
	280	225	370	240	175	140	11 x 28	26	65	ES710/6300-GL	B92090004
	280	240	370	240	190	155	11 x 28	27	74	ES710/8000-GL	B92090005
	280	255	370	240	205	170	11 x 28	33	85	ES710/10000-GL	B92090006
S-GL series	280	180	370	240	290	145	11 x 28	15	49	ES710/3150S-GL	B92090061
	280	150	420	240	290	115	11 x 28	24	59	ES710/4000S-GL	B92090062
	280	160	420	240	290	125	11 x 28	25	61	ES710/5000S-GL	B92090063
	280	175	420	240	290	140	11 x 28	26	65	ES710/6300S-GL	B92090064
	280	190	420	240	290	155	11 x 28	27	74	ES710/8000S-GL	B92090065
	280	205	420	240	290	170	11 x 28	33	85	ES710/10000S-GL	B92090066
SN-GL series	280	180	370	240	290	145	11 x 28	15	49	ES710/3150SN-GL	B92090121
	280	150	370	240	320	115	11 x 28	24	59	ES710/4000SN-GL	B92090122
	280	160	370	240	320	125	11 x 28	25	61	ES710/5000SN-GL	B92090123
	280	175	370	240	320	140	11 x 28	26	65	ES710/6300SN-GL	B92090124
	280	190	370	240	320	155	11 x 28	27	74	ES710/8000SN-GL	B92090125
	280	205	375	240	325	170	11 x 28	33	85	ES710/10000SN-GL	B92090126
Standard	240	230	325	200	180	145	11 x 28	15	49	ES710/3150	B924211
	280	200	370	240	150	115	11 x 28	24	59	ES710/4000	B924212
	280	210	370	240	160	125	11 x 28	25	61	ES710/5000	B924213
	280	225	370	240	175	140	11 x 28	26	65	ES710/6300	B924214
	280	240	370	240	190	155	11 x 28	27	74	ES710/8000	B924215
	280	255	370	240	205	170	11 x 28	33	85	ES710/10000	B924216
K series	240	–	360	200	180	145	11 x 28	15	49	ES710/3150K	B924221
	280	–	420	240	150	115	11 x 28	24	59	ES710/4000K	B924222
	280	–	420	240	160	125	11 x 28	25	61	ES710/5000K	B924223
	280	–	420	240	175	140	11 x 28	26	65	ES710/6300K	B924224
	280	–	420	240	190	155	11 x 28	27	74	ES710/8000K	B924225
	280	–	420	240	220	180	11 x 28	33	85	ES710/10000K	B924226
LG series	230	235	320	204	–	240	9 x 14	15	49	ES710/3150LG	B924231
	260	210	365	234	–	280	9 x 14	24	59	ES710/4000LG	B924232
	260	220	365	234	–	280	9 x 14	25	61	ES710/5000LG	B924233
	260	235	365	234	–	280	9 x 14	26	65	ES710/6300LG	B924234
	260	250	365	234	–	280	9 x 14	27	74	ES710/8000LG	B924235
	260	270	365	234	–	280	9 x 14	33	85	ES710/10000LG	B924236
SK2 series	380	200	450	350	270	150	11 x 16	15	69	ES710/3150SK2	B924241
	380	190	500	350	310	150	11 x 16	24	75	ES710/4000SK2	B924242
	380	200	500	350	310	160	11 x 16	25	77	ES710/5000SK2	B924243
	380	215	500	350	310	175	11 x 16	26	86	ES710/6300SK2	B924244
	380	230	500	350	310	190	11 x 16	27	90	ES710/8000SK2	B924245
	410	240	560	380	350	200	11 x 16	39	105	ES710/10000SK2	B924246
S series	280	180	370	240	290	145	11 x 28	15	49	ES710/3150S	B924261
	280	150	420	240	290	115	11 x 28	24	59	ES710/4000S	B924262
	280	160	420	240	290	125	11 x 28	25	61	ES710/5000S	B924263
	280	175	420	240	290	140	11 x 28	26	65	ES710/6300S	B924264
	280	190	420	240	290	155	11 x 28	27	74	ES710/8000S	B924265
	280	205	420	240	290	170	11 x 28	33	85	ES710/10000S	B924266

## Technical data

Type	ES710/3150	ES710/4000	ES710/5000	ES710/6300	ES710/8000	ES710/10000
<b>Power/voltages/currents</b>						
Rated power	3150 VA	4000 VA	5000 VA	6300 VA	8000 VA	10000 VA
Rated frequency	50...60 Hz	50...60 Hz	50...60 Hz	50...60 Hz	50...60 Hz	50...60 Hz
Rated input voltage	AC 230 V	AC 230 V	AC 230 V	AC 230 V	AC 230 V	AC 230 V
Rated input current	14.2 A	18 A	22.5 A	28.5 A	36 A	45.3 A
Rated output voltage	AC 230/115 V	AC 230/115 V	AC 230/115 V	AC 230/115 V	AC 230/115 V	AC 230/115 V
Rated output current	13.7 A	17.4 A	21.7 A	27.4 A	34.7 A	43.5 A
Inrush current $I_E$	$< 12 \times \hat{I}_n$	$< 12 \times \hat{I}_n$	$< 12 \times \hat{I}_n$	$< 12 \times \hat{I}_n$	$< 12 \times \hat{I}_n$	$< 12 \times \hat{I}_n$
Inrush current $I_E$ GL version	$< 5 \times \hat{I}_n$	$< 5 \times \hat{I}_n$	$< 5 \times \hat{I}_n$	$< 5 \times \hat{I}_n$	$< 5 \times \hat{I}_n$	$< 5 \times \hat{I}_n$
Leakage current	$\leq 0.5$ mA	$\leq 0.5$ mA	$\leq 0.5$ mA	$\leq 0.5$ mA	$\leq 0.5$ mA	$\leq 0.5$ mA
No-load input current $i_0$	$\leq 3$ %	$\leq 3$ %	$\leq 3$ %	$\leq 3$ %	$\leq 3$ %	$\leq 3$ %
No-load input current $i_0$ GL version	$\leq 2$ %	$\leq 2$ %	$\leq 2$ %	$\leq 2$ %	$\leq 2$ %	$\leq 2$ %
No-load output voltage $U_0$	$\leq 236$ V	$\leq 234$ V	$\leq 234$ V	$\leq 235$ V	$\leq 233$ V	$\leq 233$ V
Short-circuit voltage $U_k$	$\leq 3$ %	$\leq 3$ %	$\leq 3$ %	$\leq 3$ %	$\leq 3$ %	$\leq 3$ %
<b>Environmental conditions</b>						
Ambient temperature	$\leq 40$ °C	$\leq 40$ °C	$\leq 40$ °C	$\leq 40$ °C	$\leq 40$ °C	$\leq 40$ °C
Full-load temperature rise	$\leq 69$ K	$\leq 48$ K	$\leq 62$ K	$\leq 65$ K	$\leq 70$ K	$\leq 70$ K
Noise level (under no-load conditions and nominal load)	$\leq 35$ dB(A)	$\leq 35$ dB(A)	$\leq 35$ dB(A)	$\leq 35$ dB(A)	$\leq 35$ dB(A)	$\leq 35$ dB(A)
<b>Other</b>						
Temperature class	$t_a40/B$	$t_a40/B$	$t_a40/B$	$t_a40/B$	$t_a40/B$	$t_a40/B$
UL insulation system	class F	class F	class F	class F	class F	class F
Degree of protection	IP00	IP00	IP00	IP00	IP00	IP00
Protection class	I/II*	I/II*	I/II*	I/II*	I/II*	I/II*
Recommended use when used in accordance with DIN VDE 0100-710	25 A gL/gG	35 A gL/gG	50 A gL/gG	50 A gL/gG	63 A gL/gG	80 A gL/gG
Recommended use when used in accordance with DIN VDE 0100-710 GL version	25 A gL/gG	25 A gL/gG	35 A gL/gG	50 A gL/gG	50 A gL/gG	63 A gL/gG
Induction	0.86 T	0.94 T	1.00 T	1.05 T	1.05 T	1.05 T
$R_{\text{primary}} \pm 5$ %	0.255 $\Omega$	0.135 $\Omega$	0.100 $\Omega$	0.090 $\Omega$	0.064 $\Omega$	0.054 $\Omega$
$R_{\text{secondary}} \pm 5$ %	0.230 $\Omega$	0.110 $\Omega$	0.095 $\Omega$	0.080 $\Omega$	0.056 $\Omega$	0.045 $\Omega$
Efficiency	95 %	96 %	96 %	96 %	96 %	96 %
<b>Loss at 20...22 °C ambient temperature</b>						
Fe loss (iron loss) $\pm 10$ %	55 W	60 W	80 W	105 W	110 W	130 W
Fe loss (iron loss) GL version $\pm 10$ %	18 W	20 W	26 W	33 W	38 W	42 W
Cu loss (copper loss) $\pm 10$ %	90 W	80 W	100 W	135 W	165 W	205 W
Cu loss (copper loss) GL version $\pm 10$ %	90 W	80 W	100 W	135 W	165 W	205 W
Total loss Fe + Cu						

\* Option: completely encapsulated version  
Energy efficient version GL = Green Line

**Green Line transformer (energy efficient version) – High degree of energy saving over the life time (16 years AfA)  
(German AfA table for depreciation of wear and tear)**

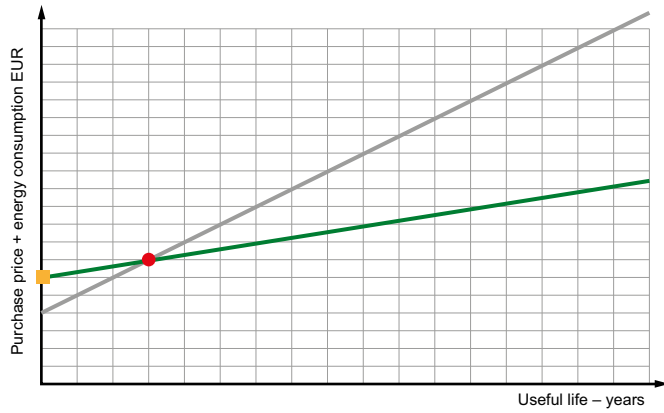

This general illustration is based on calculations of the transformer's energy consumption while energy costs remained constant at 13.4 ct/kWh (source: first energy) for 16 years. The wide variety of bandwidths result from the different transformer capacities.

Afa = Deprecation of wear and tear

— = Standard version

— = GL version (Green Line)

■ = A higher purchase price of approx. 15-20%

● = ROI (Return on Investment) after about 1-3 years

## Isolating transformer enclosure

### ESDS0107

Sheet steel enclosure in vertical position for single-phase transformers of the series ES710/3150 to ES710/10000.

#### Enclosure

- Sheet steel, varnished in RAL 7032
- Degree of protection IP 23
- Bore holes for cable entry
- The enclosures of the transformers (standard (GL) version), transformer sizes of 3.15 to 10 kVA, are provided with fixing holes intended for easy retrofitting at any time.
- The sheet steel enclosure ESDS701 is only suitable for the -LG series for hanging mounting.

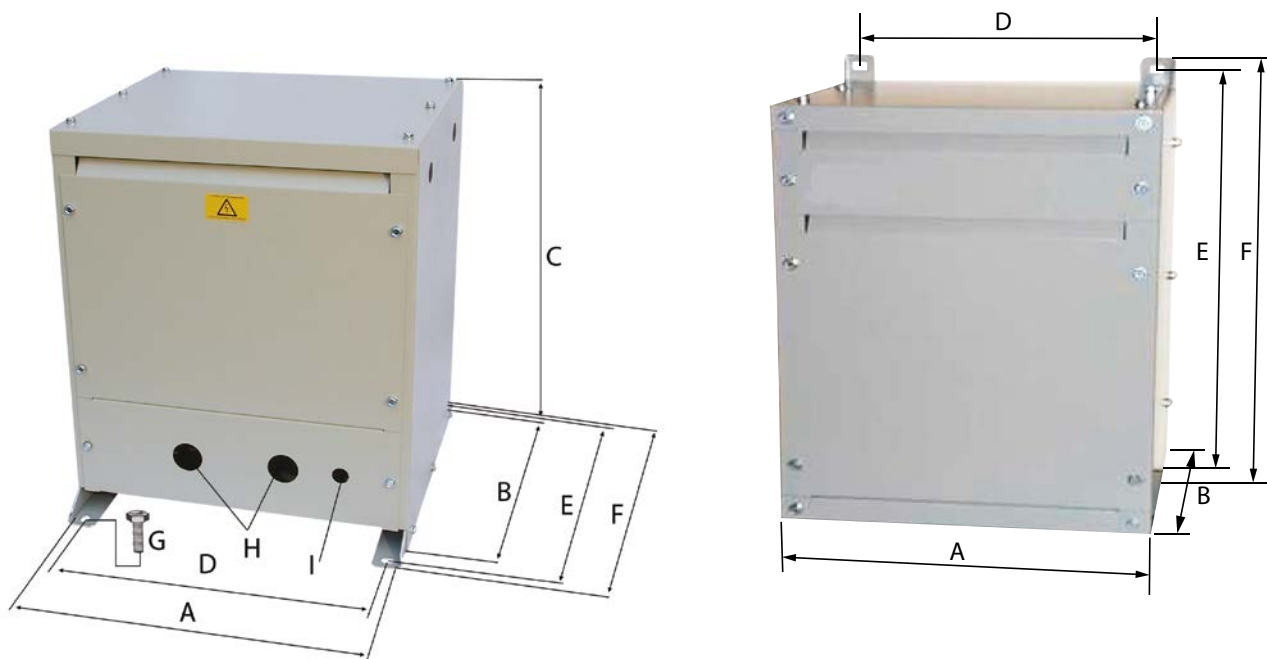

#### Ordering information enclosure

Dimensions (mm)									Weight (kg)	Version	Type	Art. No.
A	B	C	D	E	F	G	H	I				
430	380	500	385	420	450	M10	∅ 37,5	∅ 20,5	16	floor mounting	ESDS0107-1	B924673
350	300	–	315	550	580	–	–	–	18	hanging mounting	ESDS710	B924741



#### Bender GmbH & Co. KG

Londorfer Straße 65  
35305 Grünberg  
Germany

Tel.: +49 6401 807-0  
info@bender.de  
www.bender.de



© Bender GmbH & Co. KG, Germany  
Subject to change!  
The specified standards take into account the edition valid until 04.2026 unless otherwise indicated.